

PRESTO®

CoolDaddy®

cool-touch electric deep fryer

- Delicious deep fried foods, fast and easy.
- Exterior handle lowers food into the oil with the cover closed to prevent splattering.
- Large viewing window lets you supervise the frying without opening the cover.
- Removable pot for quick and easy cleaning.

Estas instrucciones también están disponibles en español.

Para obtener una copia impresa:

- Descargue en formato PDF en www.GoPresto.com/espanol.
- Envíe un correo electrónico a contact@GoPresto.com.
- Llame al 1-800-877-0441, oprima 2 y deje un mensaje.



Visit www.GoPresto.com

INSTRUCTIONS

©2018 National Presto Industries, Inc.
Form 72-713E

This is a  Listed appliance. The following important safeguards are recommended by most portable appliance manufacturers.

IMPORTANT SAFEGUARDS

To reduce the risk of personal injury or property damage, when using electrical appliances, basic safety precautions should always be followed, including the following:

1. Read all instructions.
2. Do not touch hot surfaces. Use handles.
3. Be sure handle is properly assembled to basket and locked in place. See detailed assembly instructions on page 2. Failure to securely attach the basket handle can result in the release of the basket during use, which may result in severe burns.
4. To protect against electrical shock or burns, do not immerse appliance, cord, or plug in water or other liquid.
5. Close supervision is necessary when any appliance is used by or near children.
6. Do not let children handle or put electrical cords or plugs in their mouths.
7. Always attach magnetic plug end to appliance first, then plug power cord into the wall outlet. To disconnect, remove plug from wall outlet, then magnetic plug end from appliance.
8. Unplug from wall outlet when appliance is not in use and before cleaning. Allow to cool before putting on or taking off parts, and before cleaning the appliance.
9. Do not operate any appliance with a damaged cord or plug or in the event the appliance malfunctions or has been damaged in any manner. Return the appliance to the Presto Factory Service Department for examination, repair, or electrical or mechanical adjustment. See back cover for contact information.
10. The use of accessory attachments not recommended or sold by the appliance manufacturer may cause fire, electric shock, or injuries. Use only genuine Presto™ accessory attachments or replacement parts.
11. Do not use outdoors.
12. Do not let cord hang over edge of table or counter or touch hot surfaces.
13. Do not place on or near a hot gas or electric burner or in a heated oven.
14. It is recommended that this fryer not be moved when it contains hot oil or other hot liquid. If it must be moved when it contains hot oil or other hot liquid, use extreme caution.
15. Do not use appliance for other than intended use.

SAVE THESE INSTRUCTIONS

THIS APPLIANCE IS FOR HOUSEHOLD USE ONLY.

Important Cord and Plug Information

A short power supply cord is provided to reduce the risk of becoming entangled in or tripping over a longer cord. **DO NOT USE WITH AN EXTENSION CORD.**

Do not allow the power supply cord to run underneath or around the appliance. The magnetic cord assembly may not detach easily if the power supply cord is positioned in this fashion. Connect the power supply cord to a 120VAC electrical outlet only.

Before First Use

Become familiar with the various parts of the deep fryer (Fig. A) and read the instructions carefully.

Cleaning before first use

Wipe the fryer cover and cool-touch base with a damp cloth. **CAUTION!** To avoid electrical shock, never immerse the fryer base, cord, or plug in water or other liquid. Never wash the cover or fryer base in a dishwasher.

Open the deep fryer cover by pushing the cover release button on the front of the fryer.

Remove the frying basket, basket handle, charcoal filter, and any packaging material from the deep fryer. Then lift the removable pot out of the fryer base.

Wash the basket (with the handle removed) and removable pot in hot, soapy water; rinse and dry thoroughly. Washing these parts in a dishwasher is not recommended; see pages 4 and 5 for specific cleaning instructions. **NOTICE:** If you choose to wash the removable pot in a dishwasher, it will likely discolor due to the caustic nature of the dishwasher detergent.

Positioning removable pot in fryer base

After cleaning, place the removable pot back in the fryer base. The terminal pins on the bottom of the removable pot fit in the receptacle inside the fryer base (Fig. B).

For easiest alignment, position the pot in the base so the ▼ on the front of the pot aligns with the front seam of the unit (Fig. C). Then tilt the pot forward slightly and push pot down into fryer base. If the cover closes, the pot is in the correct position.

Installing or replacing removable filter

The charcoal filter, which is located in the cover of the deep fryer, will help absorb unpleasant odors. For the deep fryer to effectively absorb these odors, always use the fryer with the filter in the cover.

To install or replace the filter, first close the fryer cover. Then, remove the filter cover (Fig. D) by pushing the release latch toward the window and lift up on the back of the filter cover.

If replacing an old filter, remove and discard it. Unwrap new charcoal filter and insert it in the filter compartment. Replace the filter cover and snap into place by pushing down. Replacement filters may be purchased through the Presto Consumer Service Department (see back cover).

Attaching basket handle to basket

Before using the deep fryer, you will need to attach the basket handle to the basket. Follow these steps:

1. Hold the basket in one hand and the basket handle in your other hand. You will be placing the pegs, which are at the ends of the two basket handle bars, into the two holes in the basket bracket (Fig. E).
2. While holding the pegs near the peg holes, tilt the handle inward before attempting to place the pegs in their holes. You will not be able to fit the second peg into its hole if the handle bars are positioned too close to the bracket.
3. Next, place one of the pegs in one of the peg holes. Then squeeze the handle bars together and fit the opposite peg in the other peg hole (Fig. F).

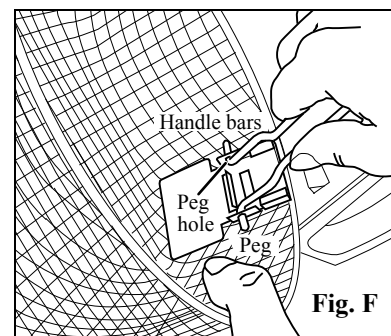
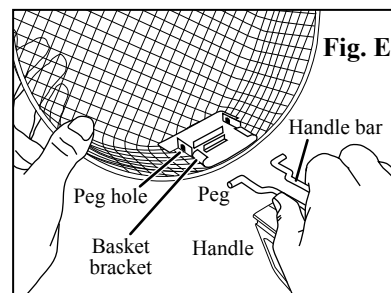
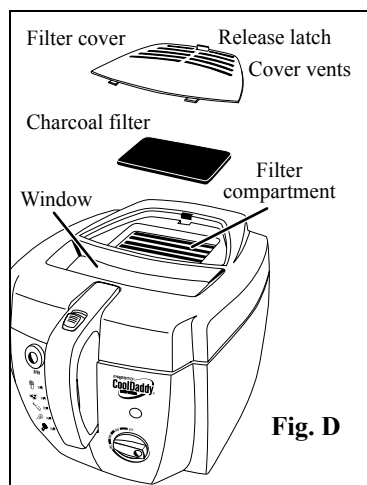
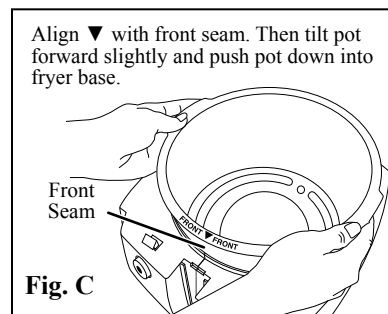
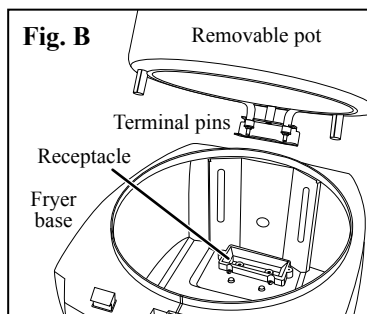
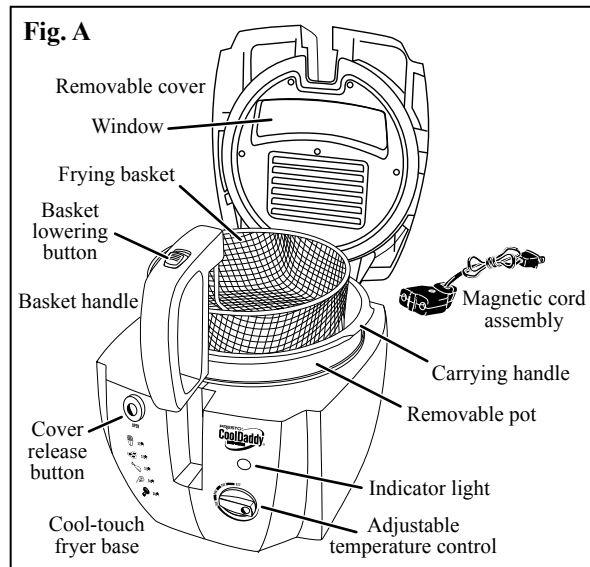

4. While squeezing the handle bars together and keeping the pegs in the holes, rotate the handle toward the basket rim, allowing the handle bars to snap into the tabs on the basket bracket (Fig. G). The handle is now in the locked position.

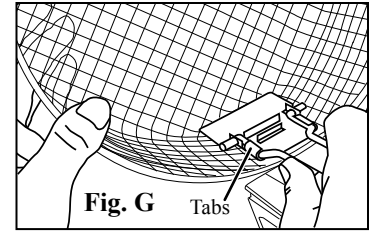

WARNING! Failure to securely attach the basket handle can result in the release of the basket during use, which may result in severe burns.

For instructions on positioning basket in fryer, see step 3 in “To fry” section on page 4.

Important Safety Information

WARNING! Burn Hazards

- Hot oil can cause serious and painful burns. Close supervision is necessary when any appliance is used by or near children.
- **Oil and water do not mix.** The combination can be dangerous. Accordingly, before pouring oil into the removable pot, be sure that the pot and all parts are COMPLETELY DRY. In addition, before placing food in deep fryer, always remove ice crystals and excess moisture from food by patting dry with paper towels. When the oil is heated, any water droplets in the oil superheat, becoming a volatile steam that can cause hot oil to spatter, boil over, or even erupt out of the deep fryer.

Uncooked potatoes contain a high percentage of moisture and extreme caution must be used when frying. Follow special frying instructions found in steps 1, 4, and 5 of the “To fry” section (page 4), in the timetable (page 6), and in the Homemade French Fries recipe (page 6).

- Use caution when frying doughs, such as beignets, donuts, dumplings, hushpuppies, and fritters. These foods may develop air bubbles during heating, which may burst and cause burns. Use the scoop provided or tongs, rather than a fork, to turn food during frying and to remove food from oil.
- Use caution when frying flour tortillas. Flour tortillas contain air bubbles. During frying, oil can become trapped within these bubbles. If not properly drained, the bubbles can burst and cause burns. Accordingly, after frying, carefully raise the tortillas out of the vegetable oil and allow oil to drain for approximately 30 seconds.

WARNING! Electrical Hazards

To avoid the risk of electrocution or severe disfiguring electrical burns:

- Do not let the cord or plug come in contact with water or other liquid.
- Do not let children handle or put electrical cords or plugs in their mouths.
- Never use the deep fryer without the removable pot.

Important Fryer Guidelines

- Use deep fryer only on a clean, dry, level, stable, and heat-resistant surface, away from the edge.
- Never preheat or use the deep fryer without or with an insufficient amount of oil. Failure to fill fryer with oil to the minimum (MIN) fill level will cause overheating and damage to the product. Also never exceed the maximum (MAX) fill level. Using more than the maximum amount may cause the oil to boil over the top of the fryer. The MIN and MAX fill levels are embossed inside the removable pot (Fig. H). The minimum amount of oil for this fryer is six, 8-ounce cups and the maximum amount is eight, 8-ounce cups.
- Use vegetable shortening or vegetable oils, such as canola, corn, sunflower, peanut, soybean, and light olive oil. These can withstand the high temperatures required for deep frying. Do not use extra virgin olive oil or other vegetable oils as they deteriorate at temperatures below those required for deep frying. Do not use butter, margarine, or lard because they have lower smoking temperatures.
- Avoid preheating the oil longer than necessary and unplug the fryer once the last batch of food has been removed. The longer the oil is heated, the more it deteriorates.
- Always remove plug from wall outlet and then from deep fryer when unit is not in use.
- Always allow fryer to cool completely with the cover closed before removing oil and before cleaning.

How to Use

To fill with oil

1. Open the deep fryer cover. If the frying basket is in the fryer, remove it and set it aside.
2. Fill the removable pot with vegetable oil or shortening up to the MAX fill level located on the inside of the removable pot (Fig. H). Use eight, 8-ounce cups of oil or four pounds of shortening. The amount of oil in the removable pot must always be between the MIN and MAX level markings. **Never exceed the MAX level mark.**

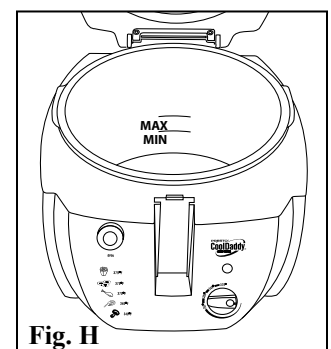

To preheat

1. Close the fryer cover. Attach the power supply cord to the fryer by aligning the magnetic plug end of the cord with the two electrical pins located in the recessed area (Fig. I) of the fryer base. When properly aligned, the magnetic plug end will attach itself magnetically to the appliance. For proper connection, the magnetic plug end must be parallel with the countertop.

IMPORTANT: The magnetic cord assembly was designed to detach easily from the fryer. As a result, if bumped or touched during use, it could detach, causing the unit to stop heating. Avoid contact with the magnetic cord assembly during operation. If contact occurs, verify it is still properly connected.

2. Plug the power supply cord into a 120VAC electrical wall outlet only. Turn the adjustable temperature control (Fig. A, page 2) to the desired temperature (page 6). The recommended temperature for most frying is 375°.

NOTE: When using the fryer for the first time, it is normal for a slight odor or light smoking to occur as manufacturing residue evaporates.

3. While oil is preheating, prepare food for frying. When the oil has reached the proper frying temperature, the indicator light will go out. Preheat time is approximately 12 minutes.

WARNING! To prevent risk of severe personal injury or property damage, use caution when frying with hot oil.

To fry

1. Place frying basket on countertop and fill up to $\frac{2}{3}$ full with food. For homemade fries, only fill basket $\frac{1}{2}$ full.
2. Push the cover release button to open the cover. If the cover does not open completely, slowly tilt the cover back to an upright position.

CAUTION! Even though the fryer has a special cool-touch exterior, the interior of the fryer is extremely hot. To avoid burns, do not touch the interior.

3. Place the filled frying basket in the removable pot, aligning the grooves on the sides of the basket handle with the slot guides on the front of the base (Fig. J and K), and lower the basket until it stops. This is the drain position.
4. With your hand on the top of the cool-touch cover, push cover down to the closed position and press until it locks in place. When frying homemade fries, leave cover in open position until basket has been completely lowered into oil.
5. Slide the basket lowering button forward and slowly lower the basket into the oil. When lowering a basket containing homemade fries, make sure the oil does not bubble up to the rim of the removable pot.

If it appears that the oil will bubble up to the rim, raise the basket and allow the oil bubbles to subside. Then slowly lower the basket again. Repeat until the basket is completely lowered into the fryer.

6. Begin timing. See frying timetable on page 6 for recommended times. During the first few minutes, it is normal for steam to appear on the viewing window. This will slowly disappear during frying if the window is kept clean between uses.

CAUTION! It is normal for steam to escape from the cover vents during frying. To prevent steam burns, keep well away from the vents.

NOTE: High moisture foods, such as french fries, produce more steam than other foods. The fryer is designed to ensure that excessive moisture does not remain in the fryer. Thus, when frying moist foods, you may see beads of condensation on the exterior of the fryer. This is normal.

7. When frying time has elapsed, lift up on the basket handle to raise the basket to the drain position.
8. Push the cover release button to open the cover. Allow the steam to vent and then slowly tilt the cover back to an upright position; **do not touch hot surfaces**. Check that the food is golden brown. If more frying time is needed, close the cover and slide the basket lowering button forward to lower the basket back into the oil.
9. Once the food is done, carefully lift the basket out of the fryer and empty food on paper towels. Season to taste.
10. If frying additional food, close fryer cover and wait for indicator light to go out. Then repeat steps 1 through 9.

Care and Cleaning

1. Remove plug from wall outlet and then from deep fryer. Allow oil and fryer to cool completely with the cover closed.
2. After unit has cooled completely, open cover. Lift the removable pot out of the deep fryer using the two carrying handles. Discard or strain oil. Refer to the section "Handling Oil after Frying" on page 5.

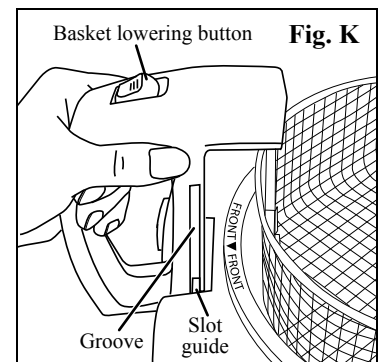
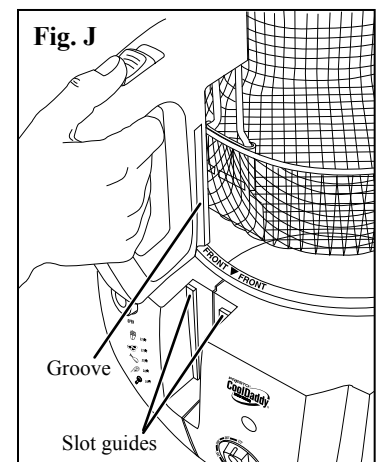
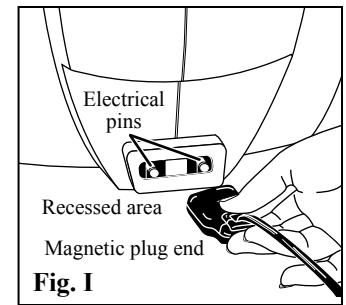

- Detach the basket handle from the basket. To detach the basket handle for cleaning, squeeze the handle bars together and tilt the handle toward the interior of the basket. While squeezing the handle bars, remove the pegs from the peg holes.
- Remove the cover from the fryer base by opening the cover and then lifting it straight up. Press the release latch on the filter cover (Fig. D, page 2) and remove the charcoal filter. **The filter should not be washed.**
- Wash the frying basket (with the handle removed), cover, and removable pot in hot, soapy water. Rinse and dry thoroughly. Dry the cover in a vertical position to allow water to drain out. **Washing these parts in a dishwasher is not recommended.** If you choose to wash the removable pot in a dishwasher, it will likely discolor due to the caustic nature of the dishwasher detergent.
- If necessary, a plastic scouring pad, such as Scotch-Brite* Dobie* Cleaning Pad, may be used to remove residue. **Do not use steel wool scouring pads or bleaching agents to clean any part of the deep fryer.**
- Wipe the cool-touch base and basket handle with a damp cloth. **Never immerse the cool-touch base or handle in water or other liquid, or wash in a dishwasher.**
- After cleaning, reassemble the unit.
- On the back side of the deep fryer is a slide-out drip cup (Fig. L). This cup collects condensation from the fryer cover when the cover is opened after frying. Empty the drip cup after each use and replace in fryer with the rib side out.
- Store the power supply cord in a clean, dry location away from metal objects. Always check the magnetic plug end before use to assure metal items have not become attached.
- Periodically check the screws on the basket handle for looseness. Retighten, if necessary, with a Phillips screwdriver. **NOTICE:** Continuing to tighten, once secure, can result in stripping of screws.

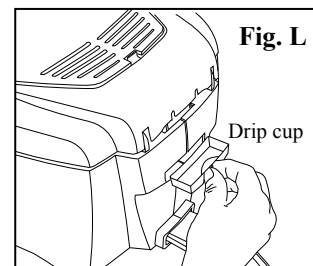

Handling Oil after Frying

After frying foods, allow oil to cool. To strain oil for reuse, place a funnel into the original oil container or other airtight container and line the funnel with a filter or a double thickness of cheesecloth. Slowly pour the oil into the funnel. Store the oil in a cool, dark area.

The number of times the oil can be reused will depend on the type of oil used and the food that is fried in it. For example, the oil will need to be replaced more often if fish or food coated with bread or cracker crumbs is fried frequently. Replace the oil if it is dark in color, has an unpleasant odor, smokes when it is heated, or foams excessively during frying.

Helpful Hints

- Fry foods of equal size and thickness as they will fry more evenly and at the same speed.
- When breading food, use any type of flour, corn meal, fine bread or cracker crumbs, or commercial breading to coat the food. To get the breading to adhere better to the food, dip the food first in a mixture of egg and milk (see Crispy Coating recipe on page 6).
- Use only heat-resistant utensils in the fryer. Hot oil damages most plastic or rubber utensils. Do not leave metal utensils in the fryer as they will become hot and can cause injury.

Questions and Answers

How do I know the removable pot is installed correctly?

If you are able to close the fryer cover tightly, the removable pot is installed correctly. If the cover does not close, reposition the pot following the instructions on page 2.

Sometimes my fryer won't heat up or it stops working while I'm frying. Why?

If your fryer fails to preheat or if the frying process stops while you are frying, check the magnetic cord assembly to assure the magnetic plug end is properly attached to the appliance (Fig. I, page 4).

The basket lowering button moves, but nothing happens. Why?

The basket is probably not positioned correctly in the fryer base. If you look at the basket handle, you will notice a long groove on each side of the handle. These grooves need to be lined up with the slot guides on the fryer base (Fig. J and K, page 4). This enables the basket to be lowered partially into the fryer. The basket lowering button is then used to lower the basket the rest of the way into the hot oil. If the handle is not positioned correctly in the slot, the basket lowering button will not function.

Whenever I make battered foods, they stick to the basket. What can I do?

Battered foods work best when fried without the basket. When using the fryer without the basket, a slotted heat-resistant scoop may be used to add or remove foods. These heat-resistant scoops may be purchased on the web at www.GoPresto.com. If, however, you want to use the basket, lower the basket into the oil before placing battered foods in the oil.

My food doesn't get as crisp as I'd like or is unevenly cooked. What am I doing wrong?

You may have overfilled the fryer. If too much food is fried at the same time, the food will not get crisp. Do not fill the basket more than $\frac{2}{3}$ full for most foods. For homemade fries, fill the basket only $\frac{1}{2}$ full. If your food is unevenly cooked, you may be frying foods that are not uniform in thickness or size. Try frying foods of equal size and thickness as they will fry more evenly and at the same speed.

*Scotch-Brite and Dobie are trademarks of 3M Company. Presto is not affiliated with this company.

Frying Timetable

The following times are approximate and based on the maximum recommended amounts of food. Fill the basket no more than $\frac{2}{3}$ full for most foods. When frying homemade fries, fill the basket only $\frac{1}{2}$ full.

TYPE OF FOOD	QUANTITY	TEMPERATURE	APPROXIMATE FRYING TIME
Cheese			
Nuggets, frozen	6 cups	375°	2 to 3 minutes
Chicken			
Nuggets, frozen	4 cups	375°	3 to 5 minutes
Pieces (serving size) raw, breaded	4 to 5 pieces	375°	12 to 18 minutes
Strips, raw, breaded	1 pound	375°	2 to 3 minutes
Donuts			
(Fry donuts without baskets)	4 to 5	375°	2 to 3 minutes
Egg Rolls			
Frozen	3 to 4	375°	5 to 6 minutes
Fish Fillets			
Frozen, battered/breaded	3 to 4	375°	5 to 7 minutes
Raw, battered*/breaded	3 to 4	375°	3 to 4 minutes
Onion Rings			
Frozen, battered/breaded	6 cups	375°	3 to 4 minutes
Fresh, battered*/breaded	6 to 8 rings	375°	1½ to 2½ minutes
Potatoes			
French fries, frozen	6 cups	375°	11 to 13 minutes
French fries, homemade	3 cups	(see recipe and procedure below)	
Shrimp			
Frozen, battered/breaded	4 cups	375°	5 to 7 minutes
Raw, battered*/breaded	1 pound	375°	2 to 5 minutes
Vegetables			
Fresh, battered*/breaded	8 to 10 pieces	375°	1 to 3 minutes

*Fresh and raw battered foods will stick to the wire mesh of the basket; therefore, it is suggested you place them directly into the oil using a long-handled scoop or tongs.

Homemade French Fries

Peel medium potatoes, if desired, and cut into $\frac{1}{4}$ to $\frac{1}{2}$ inch thick strips. Place into large bowl and cover with hot tap water. Soak potato strips for 15 minutes or until ready to fry. Rinse, drain, and pat dry with paper towels. Because uncooked potatoes contain a high percentage of moisture, extreme care must be used when deep frying. Thoroughly dry potato strips before frying.

Fill the basket $\frac{1}{2}$ rather than $\frac{2}{3}$ full. Keeping the cover open, lower the filled basket slowly into the hot oil. If the oil starts to boil up too quickly, lift the basket out of the oil for a couple of seconds. Then lower again. Repeat as necessary until the basket is completely lowered into the fryer. Close cover.

Fry at 340° for 6 to 7 minutes until fries are cooked through but not browned. Drain; let stand to cool for at least 10 minutes, but not more than 2 hours. Just before serving, fry potatoes at 375° for 10 to 12 minutes or until golden brown.

Crispy Coating

$\frac{1}{2}$ cup milk	Flour
1 egg, beaten	Salt and pepper

Beat milk and egg together in a shallow bowl. Combine flour and seasonings in another shallow bowl. Dip food into milk mixture, then coat in seasoned flour. Fry food according to timetable above.

Milk Batter

1 cup flour	2 eggs, beaten
$1\frac{1}{2}$ teaspoons baking powder	$\frac{1}{2}$ cup milk
$\frac{1}{2}$ teaspoon salt	

Combine flour, baking powder, and salt in a medium bowl. Add eggs and milk. Stir batter until smooth. If a thinner batter is desired, add more milk. Dip food in batter and fry according to timetable above. Fry milk battered foods without the basket.

Beer Batter

1½ cups flour

1½ cups beer

Thoroughly combine flour and beer in a large bowl. Cover and allow the batter to sit at room temperature for 3 hours or longer. Dip food in batter and fry according to timetable on page 6. Fry beer battered foods without the basket.

Quesadilla Crispers

¼ pound fresh sausage
(chorizo, Italian, etc.)

1 cup refried beans

¼ cup finely chopped onion

¼ cup diced canned green chiles, drained

¼ pound jalapeño jack cheese,
shredded (1 cup)

8 (7-inch) flour tortillas

1 tablespoon flour

2 tablespoons cold water

Cook sausage until done, breaking it up as it cooks. Combine sausage, beans, onion, chiles, and cheese in a separate bowl. *Makes about 1½ cups.*

Cut tortillas into quarters. Place about 1 teaspoon of bean mixture in center. Brush edges with mixture of flour and water. Fold in half and press to seal; keep covered as you work. Continue until all are made. *Makes 32.*

Let stand 5 minutes before frying to allow edges to stick together. Fry 3 or 4 at a time at 375° for 2 minutes. Drain on paper towels.

Apple Pie Fritters

1 cup all-purpose flour

2 tablespoons sugar

1½ teaspoons baking powder

¼ teaspoon salt

¾ cup milk, minus 1 tablespoon

1 tablespoon brandy

1 egg yolk

1 tablespoon butter, melted

½ teaspoon ground cinnamon

4 tablespoons sugar

3 to 4 apples, peeled, cored, sliced ¼ inch thick

2 teaspoons ground nutmeg

2 egg whites

Combine flour, sugar, baking powder, and salt in a medium bowl. Whisk milk, brandy, egg yolk, and melted butter in a second bowl. Gradually stir into dry ingredients until smooth. Set aside.

Combine cinnamon and sugar. Sprinkle over both sides of apple slices, saving remainder to dust over finished fritters. Sprinkle slices lightly with nutmeg.

In clean bowl, beat egg whites until stiff, but not dry. Fold into reserved batter.

Dip several apple slices into batter to coat evenly, letting excess drip off.

Carefully place 4 to 5 slices at a time into preheated oil. Fry at 375° for 3 to 4 minutes, turning once. Drain on paper towels. Sprinkle both sides with reserved cinnamon and sugar mixture. Best served warm.

Jalapeño Kickers

12 fresh jalapeño peppers or
1 (3½ oz) can jalapeño peppers

Cream Cheese

½ cup flour

½ cup milk

1 egg

2 tablespoons bread crumbs

¼ teaspoon vegetable oil

¼ teaspoon onion salt

⅛ teaspoon garlic salt

¼ cup flour

1 teaspoon sugar

CAUTION! Wear plastic gloves when working with peppers. Do not touch eye area.

To prepare fresh jalapeño peppers:

Rinse and cut in half lengthwise. Remove seeds and stems. Place in boiling water; remove after 2 minutes. Drain well.

To prepare canned jalapeño peppers:

Drain. Cut in half lengthwise. Remove seeds and stems.

Fill each pepper half with cream cheese until slightly rounded.

Place ½ cup flour in separate bowl, set aside. Beat milk and egg together in another bowl; set aside. Make breading by combining bread crumbs, oil, onion salt, and garlic salt in another bowl. Stir in flour and sugar until mixed thoroughly; set aside.

Roll each pepper in flour, dip in egg mixture, and then cover with breading. For a heavier breading, dip in egg mixture again and cover with breading a second time. Gently set aside until ready to fry.

Fry at 375° approximately 1 to 2 minutes or until golden brown. Remove immediately if cream cheese filling appears through the coating. Place fried peppers on paper towels. Serve warm. If desired, serve with salsa.

Variations:

Substitute shredded cheddar cheese for cream cheese filling and pack firmly.

Substitute a mixture of cream cheese and shredded cheddar cheese for cream cheese filling.

Consumer Service Information

If you have any questions regarding the operation of your Presto® appliance or need parts for your appliance, contact us by any of these methods:

- Call 1-800-877-0441 weekdays 8:00 AM to 4:00 PM (Central Time)
- Email us through our website at www.GoPresto.com/contact
- Write: National Presto Industries, Inc., Consumer Service Department
3925 North Hastings Way, Eau Claire, WI 54703-3703

Inquiries will be answered promptly by email, telephone, or letter. When emailing or writing, please include a phone number and a time when you can be reached weekdays if possible.

When contacting the Consumer Service Department, please indicate the model and series numbers for the deep fryer. These numbers can be found on the bottom of the unit. Please record this information:

Model _____ Series _____ Date Purchased _____

The Presto Factory Service Department is equipped to service Presto® appliances and supply genuine Presto™ parts. Genuine Presto™ replacement parts are manufactured to the same exacting quality standards as Presto® appliances and are engineered specifically to function properly with its appliances. Presto can only guarantee the quality and performance of genuine Presto™ parts. “Look-alikes” might not be of the same quality or function in the same manner. To ensure that you are buying genuine Presto™ replacement parts, look for the Presto® trademark.

Canton Sales and Storage Company, Presto Factory Service Department
555 Matthews Drive, Canton, MS 39046-3251

Product Registration

IMPORTANT: Please go online and register this product within ten days of purchase. Proper registration will serve as proof of purchase in the event your original receipt becomes misplaced or lost. Registration will not affect warranty coverage, but may expedite processing of warranty claims. The additional information requested will help us develop new products that best meet your needs and desires. To register your product, visit www.GoPresto.com/registration or simply scan this QR code. If you do not have computer access, call the Consumer Service Department at 1-800-877-0441.



Presto® Limited Warranty

(Applies only in the United States)

This quality Presto® appliance is designed and built to provide many years of satisfactory performance under normal household use. Presto pledges to the original owner that should there be any defects in material or workmanship during the first year after purchase, we will repair or replace it at our option. Our pledge does not apply to damage caused by shipping. ***Outside the United States, this limited warranty does not apply.***

To obtain service under the warranty, please call our Consumer Service Department at 1-800-877-0441. If unable to resolve the problem, you will be instructed to send your Presto® appliance to the Presto Factory Service Department for a quality inspection; shipping costs will be your responsibility. When returning an appliance, please include your name, address, phone number, and the date you purchased the appliance as well as a description of the problem you are encountering with the appliance.

We want you to obtain maximum enjoyment from using this Presto® appliance and ask that you read and follow the instructions enclosed. Failure to follow instructions, damage caused by improper replacement parts, abuse, misuse, disassembly, alterations, or neglect will void this pledge. This warranty gives you specific legal rights, and you may also have other rights which vary from state to state. This is Presto's personal pledge to you and is being made in place of all other express warranties.

National Presto Industries, Inc.
Eau Claire, WI 54703-3703

Form 72-713E