

PRESTO® Stuffer™ stuffed waffle maker

- Cooks Belgian-style waffles with your favorite toppings baked inside.
- The easy way to make fluffy, delicious waffles stuffed with sweet and savory foods including fruits, pie fillings, candy, cheese, meats and more.
- Flips 180° to evenly spread batter for stuffed waffles that are crispy outside and fluffy, tender inside.



For more delicious recipes
and information, scan this
QR code.

Estas instrucciones también están disponibles en español.

Para obtener una copia impresa:

- Descargue en formato PDF en www.GoPresto.com/espanol.
- Envíe un correo electrónico a contact@GoPresto.com.
- Llame al 1-800-877-0441, oprima 2 y deje un mensaje.

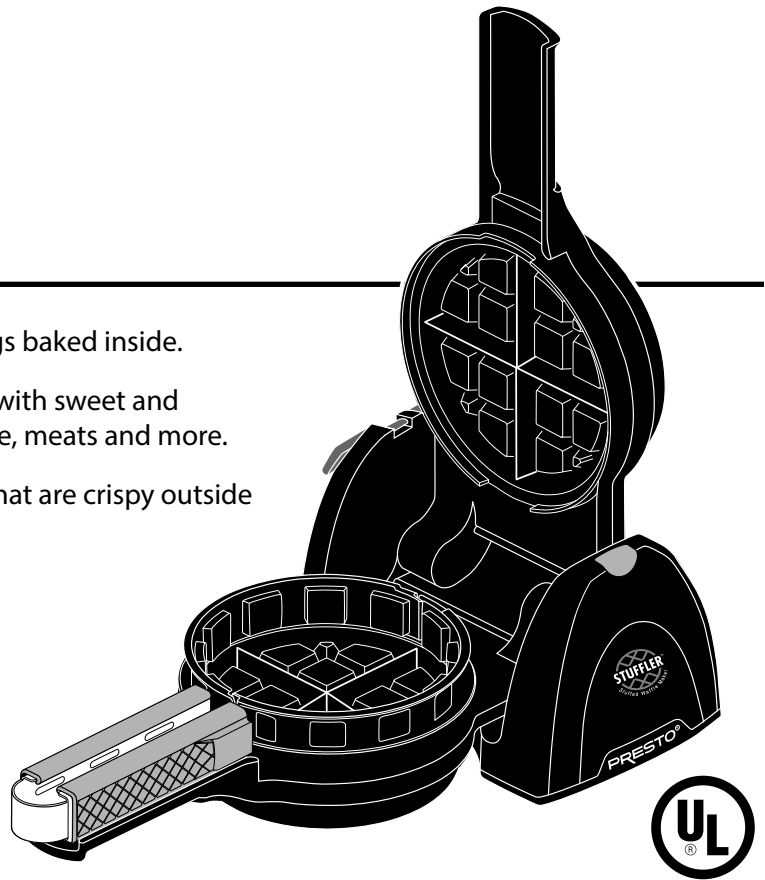

INSTRUCTIONS

Visit www.GoPresto.com

This is a  Listed appliance. The following important safeguards are recommended by most portable appliance manufacturers.

IMPORTANT SAFEGUARDS

To reduce the risk of personal injury or property damage when using electrical appliances, basic safety precautions should always be followed, including the following:

1. Read all instructions before using the waffle maker.
2. Do not touch hot surfaces. Use handles or knobs.
3. To protect against the risk of electrical shock, never put the cord, plug, or unit in water or other liquids.
4. Close supervision is necessary when any appliance is used by or near children.
5. Unplug from outlet when not in use and before cleaning. Allow to cool before putting on or taking off parts, and before cleaning the appliance.
6. Do not operate any appliance with a damaged cord or plug or in the event the appliance malfunctions or has been damaged in any manner. Return the appliance to the Presto Factory Service Department for examination, repair, or electrical or mechanical adjustment.
7. The use of accessory attachments not recommended or sold by the appliance manufacturer may cause injuries. Use only genuine Presto® accessories and replacement parts.
8. Do not let cord hang over edge of table or counter or touch hot surfaces.
9. Do not use outdoors.
10. Do not place on or near a hot gas or electric burner or in a heated oven.
11. It is recommended that this appliance not be moved when it contains hot oil or other hot liquid.
12. Do not use this appliance for other than intended use.

SAVE THESE INSTRUCTIONS

THIS APPLIANCE IS FOR HOUSEHOLD USE ONLY.

Important Cord Information

This appliance has a polarized plug (one blade is wider than the other). To reduce the risk of electric shock, this plug is intended to fit into a polarized outlet only one way. If the plug does not fit fully into the outlet, reverse the plug. If it still does not fit, contact a qualified electrician. Do not attempt to modify the plug in any way.

A short power supply cord is provided to reduce the risk of becoming entangled in or tripping over a longer cord. Extension cords may be used if care is properly exercised in their use.

If an extension cord is used, the marked electrical rating of the extension cord should be at least as great as the electrical rating of the appliance. The cord should be arranged so that it will not drape over the countertop or tabletop where it can be pulled on by children or tripped over unintentionally.

Connect the power supply cord to a 120VAC electrical outlet only.

Getting Acquainted

Before using for the first time, become familiar with the waffle maker features (Fig. A). Wash the waffle tongs and wipe the waffle grids with a damp cloth before initial use.

How to Use

1. Gather the ingredients for the batter and filling. Do any prep work required for the filling, such as thawing, cooking, or slicing of foods. (See pages 3 through 6 for helpful hints, recipes, and batter/filling options.)
2. Place the waffle maker on the countertop in the open position. Then squeeze the waffle tongs handle and fit the waffle tongs in the unit; the circular portion fits on the ledge surrounding the grids and the handle sets on the handle rest (Fig. A). Always preheat the waffle maker with the waffle tongs in the unit (Fig. B).

3. Close the unit and keep it in the horizontal position for preheating (Fig. D, page 3). Plug the cord into a 120VAC electrical outlet and preheat for 10 minutes. (The power light will be on whenever the unit is plugged in.)

NOTE: When using the waffle maker for the first time, a slight odor or smoking may occur as internal manufacturing residue burns off. This is normal during initial use.

4. While the unit is heating, prepare the waffle batter.

NOTE: Because the grids are covered with a nonstick finish, there should never be a need to apply vegetable oil, except in the rare instances described in the Helpful Hints section. Never use no-stick cooking sprays.

5. Open the waffle maker. Pour batter into the waffle maker so that the bottom grids and waffle divider are thinly, but completely covered. This is about $\frac{1}{3}$ cup of batter.

6. Add the desired filling:

- Fill to the point that is halfway between the bottom and top of the square projections (Fig. C). It is important to leave enough room so you can fully cover the filling with the layer of batter described in step 7.
- Leave a thin margin between the filling and the inside edge of the tongs (Fig. C).

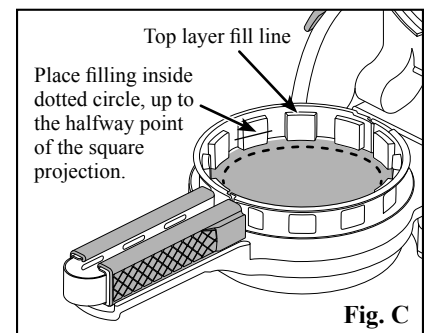
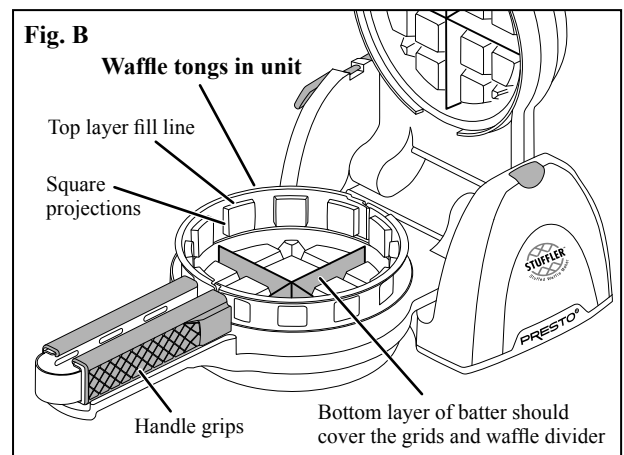
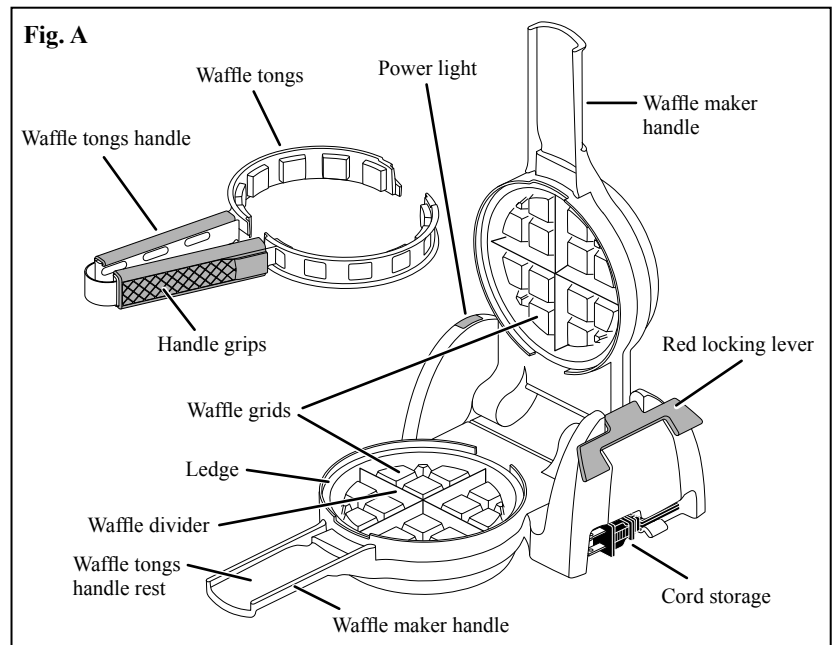

- When a sauce is part of the filling, layer the sauce between the other ingredients, such as the cheese or meat, instead of putting it directly on the batter.
- Fruits/vegetables should be room temperature if using for filling. If fruits/vegetables have been frozen and thawed, drain them before use. If using canned fruits/vegetables, drain before use.

IMPORTANT: Fillings such as meats, chicken, and eggs should be cooked and frozen foods thawed before using them to make waffles. The baking time is not long enough nor is the temperature hot enough to adequately cook food or heat frozen food used for filling.

- Pour additional batter over the filling until it is to the top of the square projections on the waffle tongs (Fig. C) and covers the filling.
- Close the waffle maker (Fig. D). Immediately grasp the handles and flip the unit over 180° (Fig. E and Fig. F).** This allows the batter to flow into the waffle grids to make a fully formed waffle.
- Set a timer (see waffle recipes and stuffing ideas on pages 4 through 6 for cooking times). Most waffle batters will take 7 to 8 minutes. Cake mixes and cake batter made from scratch will take approximately 7½ minutes to cook.

NOTE: When cooking waffle batters that contain several eggs, you may notice the handles separate as the batter cooks. This is normal.

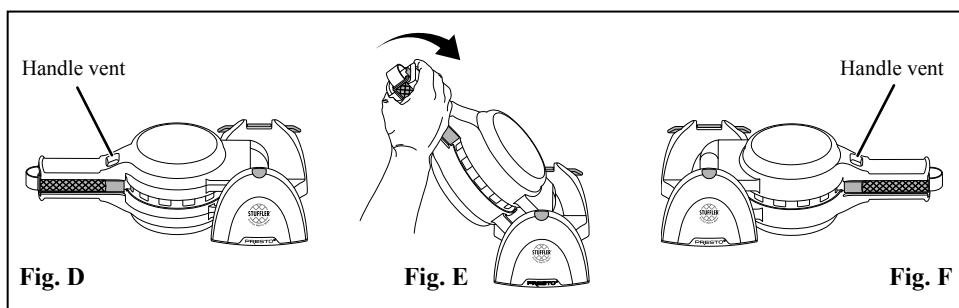

CAUTION! It is normal for steam to escape from the handle vent during cooking. To prevent steam burns, keep well away from the vent.

- When set time has expired, open the waffle maker. Grasping the red handle grips, squeeze the tongs and lift the waffle out of the unit. Release the waffle onto a serving plate (Fig. G). The outer band of the waffle has its own distinctive pattern and is lighter in appearance than the rest of the waffle. This is normal.

CAUTION! To avoid burns, do not touch the metal parts on the waffle tongs.

- Place the tongs back in the unit and heat in the closed position while preparing for the next waffle. Repeat steps 5 through 10.
- Unplug the waffle maker when cooking is complete. Clean as instructed on page 7.

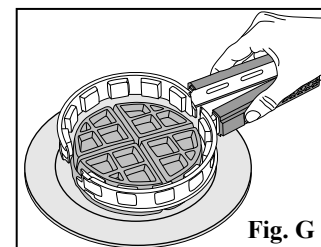

Helpful Hints

- ◆ There are many choices for waffle batter. You can use one of the batter recipes found on pages 5 and 6 or one of your own recipes. If preferred, packaged pancake and waffle mixes, all-purpose baking mixes, cake mixes, and muffin mixes can be used. One batch of batter from a packaged mix will make about three stuffed waffles.
- ◆ For batters that are thick and do not pour easily, place spoonfuls of batter onto the waffle grid. Then use a heat-resistant spatula to spread the batter out evenly to the edge of the grid.
- ◆ Traditional waffles without filling can be baked, if desired. Each waffle will require about ¼ cups of batter and baking time will be 7½ to 8 minutes.
- ◆ Keep waffles warm and crisp until serving by placing them in a single layer directly on a rack in a 200°F oven.
- ◆ For most batters, oiling is unnecessary and may actually reduce the waffle maker's nonstick qualities. However, when using a made-from-scratch batter that has no added fat (e.g. substitutes applesauce for oil) or contains minimal oil (less than 1 tablespoon), apply a light coating of vegetable oil to the waffle grids before cooking the first waffle. That will prevent sticking. For additional waffles, apply only as needed. Never use no-stick cooking sprays. They leave a tacky residue and will give the waffle a mottled appearance rather than an even brown appearance.

Recipe Ideas (Cook 7 to 8 minutes)

VARIETY	BATTER	FILLING PER WAFFLE	TOPPING/SIDES
SAVORY			
Chicken & Waffles	Classic waffle*	One layer cooked chicken strips	Honey or maple syrup
Corn Fritter	Cornmeal waffles with cheese and chiles (see page 6)	½ cup Southwest-style corn, several jalapeño slices, 2 tablespoons salsa	
Mediterranean	Classic waffle* with 1 teaspoon Italian seasoning added per batch	Single layer of each: spinach leaves, roasted red pepper strips, sliced olives, 3 tablespoons feta crumbles	
Pizza	Classic waffle* with 1 teaspoon Italian seasoning added per batch	8 slices pepperoni, 2 slices mozzarella cheese, 2 tablespoons pizza sauce	
Spinach Artichoke	Classic waffle*	⅓ cup prepared spinach artichoke dip, 2 slices mozzarella cheese	
Reuben	Classic waffle* with 1 teaspoon caraway seed added per batch	2 slices Swiss cheese, 2 slices corned beef, ¼ cup drained sauerkraut	Thousand Island dressing
BREAKFAST			
Avocado	All-purpose baking mix	1 egg (scrambled), 2 slices pepper jack cheese, 5 slices avocado	
Classic	All-purpose baking mix	1 egg (scrambled), 2 slices cheddar cheese, 2 sausage patties	
FRUIT			
Banana Pecan	Classic waffle* Pecan waffle (see page 6)	2 tablespoons chopped pecans, ½ cup sliced banana	
Triple Berry	Classic waffle* Pecan waffle (see page 6)	½ cup fresh or frozen, drained mixed berries (blueberries, raspberries, and blackberries)	
DESSERT			
Cherry Pie	Classic waffle*	½ cup cherry pie filling	Whipped topping
Peach Pie	Classic waffle* with 1 teaspoon cinnamon added per batch	½ cup peach pie filling	Whipped topping
S'mores	Classic waffle*	2 Mallo Cups** (candy) and 1 graham cracker, all broken into pieces	
Turtle Cheesecake	Chocolate cake batter	¼ cup refrigerated no-bake cheesecake filling, 2 tablespoons chopped pecans, 2 tablespoons chocolate chips	Caramel sauce drizzle

*See recipe for Classic Waffle Batter on page 5 or use packaged pancake or waffle mix.

**Mallo Cup is a registered trademark of The Boyer Candy Company, Inc. Presto is not affiliated with this company.

Batter options:

Waffle batter recipes (see below and page 6), packaged pancake and waffle mixes, all-purpose baking mixes, cake mixes, muffin mixes

Batter mix-in options:

Stir 1 teaspoon spice, herb, or seasoning into batch of waffle batter. Cinnamon pairs well with fruit filling. Italian seasoning goes well with pizza and Mediterranean fillings.

The addition of 2 teaspoons of vanilla and ¼ teaspoon of almond extract provides a cake-like flavor for fruit and dessert waffles.

Filling options:

The total amount of filling generally should not exceed ½ cup to prevent overfilling.

MEAT (*Raw or frozen meat must be cooked before adding to waffle.*)

Bacon, Canadian bacon, chicken strips, ham, pepperoni, pulled pork, sausage

CHEESE

American, Cheddar, feta, Monterey Jack, mozzarella, provolone, Pepper Jack, Swiss

FRUIT (*Frozen fruit must be thawed and drained thoroughly before adding to waffle.*)

Apple, banana, peach, pineapple, and strawberry slices; berries (such as blackberries, blueberries, and raspberries); pie filling; dried cranberries; raisins

VEGETABLES

Avocado, olives, green onion, and pepperoncini slices; diced red and green peppers; cilantro; spinach leaves

CANDY

Chocolate (chocolate chips, candy coated chocolate pieces, chocolate-coated caramel-peanut nougat bar, chocolate-covered peanut butter cups, English toffee-flavored candy bars); crushed peppermint candy; gummies and gum drops; caramel bits; marshmallows

*For additional stuffing ideas and recipes,
simply scan this QR code.*



Batter Recipes

Classic Waffles

2 cups all-purpose flour	1¾ cups milk
1 tablespoon sugar	2 eggs
1 tablespoon baking powder	3 tablespoons vegetable oil
¼ teaspoon salt	

Mix flour, sugar, baking powder, and salt in a large bowl. Whisk milk, eggs, and oil in a medium bowl. Whisk milk mixture into dry ingredients just until dry ingredients are thoroughly moistened. Preheat waffle maker with waffle tongs in unit. Follow instructions on pages 2 and 3, cooking waffles for 7 minutes.

About 4 stuffed waffles

Variation: If using this recipe for fruit or dessert waffles, you may wish to add 2 teaspoons vanilla extract and ¼ teaspoon almond extract.

Cornmeal Waffles with Cheese and Chiles

1 cup all-purpose flour	2 eggs, separated
$\frac{3}{4}$ cup yellow cornmeal	2 cups buttermilk
2 teaspoons baking powder	2 tablespoons vegetable oil
1 teaspoon baking soda	3 tablespoons canned green chiles, drained
$\frac{1}{8}$ teaspoon salt	1 cup shredded sharp cheddar cheese

Mix flour, cornmeal, baking powder, baking soda, and salt in a large bowl. Stir in egg yolks, buttermilk, oil, chiles, and cheese. Beat egg whites until stiff in a medium bowl using an electric mixer. Fold whites into batter, leaving a few fluffs. Preheat waffle maker with waffle tongs in unit. Follow instructions on pages 2 and 3, cooking waffles for 7 minutes.

About 4 stuffed waffles

Pecan Waffles

2 cups all-purpose flour	$\frac{1}{4}$ cup chopped pecans
2 tablespoons packed brown sugar	2 cups buttermilk
2 teaspoons baking powder	2 eggs
1 teaspoon baking soda	3 tablespoons vegetable oil
$\frac{1}{4}$ teaspoon salt	$\frac{1}{2}$ teaspoon maple extract

Mix flour, brown sugar, baking powder, baking soda, and salt in a large bowl. Stir in pecans. Whisk buttermilk, eggs, oil, and maple extract in a medium bowl. Whisk milk mixture into dry ingredients just until dry ingredients are thoroughly moistened. Preheat waffle maker with waffle tongs in unit. Follow instructions on pages 2 and 3, cooking waffles for 6½ minutes.

About 5 stuffed waffles

Cauliflower, Egg, and Cheese Waffles (keto and gluten-free)

7 eggs	$\frac{1}{4}$ teaspoon black pepper
4 cups fresh riced cauliflower*	$\frac{1}{2}$ teaspoon Italian seasoning or desired seasoning blend
$\frac{1}{2}$ cup almond flour	$\frac{2}{3}$ cup shredded sharp cheddar cheese
2 teaspoons baking powder	
1 teaspoon onion salt	

Whisk eggs in a medium bowl. Stir in cauliflower, flour, baking powder, onion salt, pepper, and Italian seasoning. Fold in cheddar cheese. Preheat waffle maker with waffle tongs in unit. Follow instructions on pages 2 and 3, cooking waffle for 7½ minutes. Remove waffle and allow to rest for 1 minute before serving.

NOTE: This batter is thick, so spoon it into the waffle maker and then spread it out. Handles may separate during cooking as eggs rise. This is normal.

About 5 stuffed waffles

*Riced cauliflower is commercially available in the produce department at most grocery stores.

Questions and Answers

1. I put too much filling in my waffle and it oozed out of the waffle. Some of the filling is now baked onto the grids. How do I clean the grids?

Please refer to #3 in the Care, Cleaning, and Storage section on page 7. Next time reduce the amount of filling.

2. The tongs don't lift the baked waffle out of the waffle maker. Why?

The waffle is too heavy with filling. It will be necessary to reduce the amount of filling for the next waffle. Generally, $\frac{1}{2}$ cup of filling can be used.

3. When I lift the tongs with the baked waffle, the waffle separates and only the top half of the waffle comes out. What I am doing wrong?

The waffle may have too much filling or has not been baked long enough. Bake the waffle for another 30 seconds to 1 minute to allow the waffle to cook through.

4. Can I use puréed fruit like applesauce in place of oil in the batter recipes?

Yes, waffles can be made successfully using puréed fruit as a substitute for oil. Because there is no oil in the recipe, it is suggested that the waffle grids be brushed lightly with vegetable oil to prevent sticking.

5. Where can I find more recipes?

Please scan the QR code found on page 5 periodically for more recipes and filling suggestions.

6. Can I use gluten free or keto waffle batter in the stuffed waffle maker?

Yes, gluten free flour and nut flours can be used to make batters to use in the waffle maker.

Care, Cleaning, and Storage

1. Unplug the waffle maker and allow to cool completely before cleaning.
2. To clean the waffle maker, brush any loose crumbs from the waffle grids. Then wipe the grids with a paper towel or cloth. Clean the outside of the waffle maker with a damp cloth.

Should any batter become baked onto the grids or the outside of the unit, apply a small amount of vegetable oil to the baked-on batter. Allow it to sit for a few minutes to soften and wipe off with a paper towel or cloth. Do not use steel wool scouring pads or abrasive kitchen cleaners on the unit. **Never immerse the waffle maker base in water or other liquid.**

3. If filling oozes out of the stuffed waffle during baking, it may be necessary to perform a more thorough cleaning of the waffle grids. Unplug the waffle maker and add 1 tablespoon of water to the bottom grid. Close the unit and without flipping, allow it to cool to a comfortable temperature. Then, using the dampness remaining on the grids, wipe away the residue.
4. Wash the waffle tongs in hot, soapy water, and rinse thoroughly. Do not wash the tongs or waffle maker in the dishwasher.
5. Place the waffle tongs in the waffle maker and close the unit.
6. Push the cord into the cord storage port and secure the plug end in the clip (Fig. H).
7. For compact storage, grasp the waffle maker handles and rotate the waffle maker to the vertical position. While holding the handles together, rotate the red locking lever until it secures the unit in the upright position (Fig. I and Fig. J).

Before the next use, remember to unlock from the storage position (Fig. J). Hold the handles together and rotate the red locking lever towards the cord storage (Fig. I).

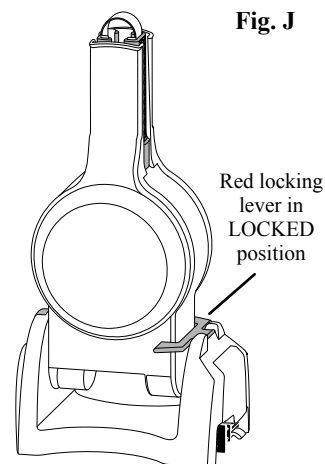
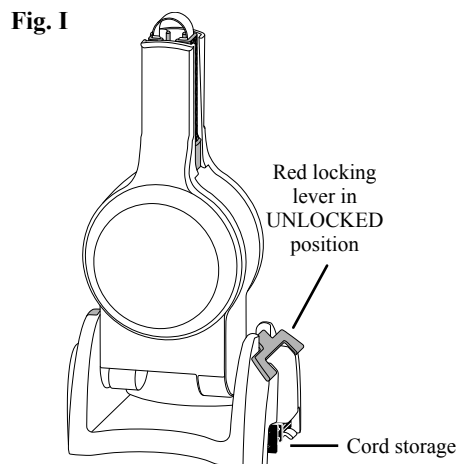
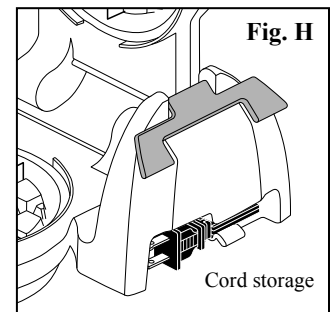

Consumer Service Information

If you have any questions regarding the operation of your Presto® appliance or need parts for your appliance, contact us by any of these methods:

- Call 1-800-877-0441 weekdays 8:00 AM to 4:00 PM (Central Time)
- Email us through our website at www.GoPresto.com/contact
- Write: National Presto Industries, Inc., Consumer Service Department
3925 North Hastings Way, Eau Claire, WI 54703-3703

Inquiries will be answered promptly by telephone, email, or letter. When emailing or writing, please include a phone number and a time when you can be reached during weekdays if possible. When contacting the Consumer Service Department, please indicate the model and series numbers for the waffle maker. These numbers can be found on the bottom of the waffle maker.

Please record this information:

Model _____ Series _____ Date Purchased _____

The Presto Factory Service Department is equipped to service Presto® appliances and supply genuine Presto® replacement parts. Genuine Presto® replacement parts are manufactured to the same exacting quality standards as Presto® appliances and are engineered specifically to function properly with its appliances. Presto can only guarantee the quality and performance of genuine Presto® replacement parts. “Look-alikes” might not be of the same quality or function in the same manner. To ensure that you are buying genuine Presto® replacement parts, look for the Presto® trademark.

Canton Sales and Storage Company
Presto Factory Service Department
555 Matthews Drive, Canton, MS 39046-3251

Product Registration

IMPORTANT: Please go online and register this product within ten days of purchase. Proper registration will serve as proof of purchase in the event your original receipt becomes misplaced or lost. Registration will not affect warranty coverage but may expedite the processing of warranty claims. The additional information requested will help us develop new products that best meet your needs and desires. To register the product, visit www.GoPresto.com/registration or simply scan this QR code. If you do not have computer access, contact the Consumer Service Department at 1-800-877-0441.



Presto® Limited Warranty

(Applies only in the United States)

This quality Presto® appliance is designed and built to provide many years of satisfactory performance under normal household use. Presto pledges to the original owner that should there be any defects in material or workmanship during the first year after purchase, we will repair or replace it at our option. Our pledge does not apply to damage caused by shipping. ***Outside the United States, this limited warranty does not apply.***

To obtain service under the warranty, please call our Consumer Service Department at 1-800-877-0441. If unable to resolve the problem, you will be instructed to send your Presto® appliance to the Presto Factory Service Department for a quality inspection; shipping costs will be your responsibility. When returning an appliance, please include your name, address, phone number, and the date you purchased the appliance as well as a description of the problem you are encountering with the appliance.

We want you to obtain maximum enjoyment from using this Presto® appliance and ask that you read and follow the instructions enclosed. Failure to follow instructions, damage caused by improper replacement parts, abuse, misuse, disassembly, alterations, or neglect will void this pledge. This warranty gives you specific legal rights, and you may also have other rights which vary from state to state. This is Presto's personal pledge to you and is being made in place of all other express warranties.

National Presto Industries, Inc.
Eau Claire, WI 54703-3703